

## **An Examination of the Relationships between Materialism, Consumer Ethnocentrism and Cosmopolitanism in Romania**

by

Bogdan Robert Ioane

bogdan.ioane@gmail.com

*Abstract.* Over the last years, East European consumers seem to have become more and more “modern”, demanding and complex, endorsing the fact that major changes happen in consumer evolution of developing ex-communist countries. As well as in other East European countries, Romania too experiences a trend of rapid, major changes.

At the same time, increasing levels of materialism are associated with periods and places undergoing rapid social and cultural change. Researchers agree that materialism is neither unique to western cultures nor related to affluence. From this perspective, in Romania, the deprivations under communism cultivated ample feelings of legitimate deservingness, and materialism has quickly been accepted by consumers.

In general, materialism values and individuals are seen negatively, considered bad or even evil. Materialism is seen as a false path to happiness via consumption, a weakness arising from insecurity, a type of harmful competition for status through possessions, and a valuation of things over people. Despite these negative connotations of materialism, studies show increasing consumption patterns and aspirations that appear as highly materialistic. In research, Romanians were the least likely to see materialism as a weakness, stressing the utilitarian aspects of materialism in which goods are purchased to accomplish tasks, and possessions are seen as means to an end.

The literature describing the materialism levels for the Romanian market seems to be outdated; the present study intends to update the knowledge regarding Romanian consumers’ materialism levels.

*Key words:* materialism, consumer ethnocentrism, cosmopolitanism, Romania

JEL classification: Consumer economics D11, Marketing M31

### **1 Introduction**

After decades of deprivation under the communist Ceausescu regime, many Romanians experienced changes in their perspectives and worldviews, as they moved from having very little to the consumption-related feelings of prosperity. Romanians changed the communist system with a democratic one in 1989; before that, people could be happy with few material goods because there were no alternatives, and everyone had few possessions. During the communist regime, there were few consumer goods available, and the western life style was frowned upon. Before the 1989 revolution, consumption was centered on literature, music and art, a focus that was displaced by a tide of materialism after the overthrowing of the communist regime (Ger & Belk, 1999).

Before 1989, in order to erase the country’s international debt, Ceausescu imposed 15 years of severe rationing of food, heat, water, electricity, gas, and other basics. Queues were ubiquitous for bread, flour, milk, sugar, meat,

and shortages were frequent for most consumer goods. After 1989, consumer goods were suddenly made available. After years of hard deprivation, the temptation of newly available goods, especially the previously banished fruits of Western culture are highly seductive (Ger & Belk, 1996). After the revolution, the economy grew, as suggested by Herman (2008) who identified two major growth periods in Romania: between 1993-1996 and 2000-2006 (Herman, 2008). This economic growth increased the disposable income, together with consumption levels for most consumer goods.

Ger and Belk (1996) suggest that higher levels of materialism are associated with periods and places undergoing rapid social and cultural change. On the basis of a study of 12 countries, they concluded that materialism is neither unique to western cultures nor related to affluence (Ger & Belk, 1996). From this perspective, in Romania, the deprivations under communism cultivated ample feelings of legitimate deservingness. Ger and Belk observed that each culture finds a culturally

appropriate way to justify its own high level consumption behavior and aspirations - their findings suggest that everyone has a yardstick with which they measure what level and pattern of consumption is enough and good and call most others "materialistic" (Ger & Belk, 1999). In a similar note, materialism has quickly become accepted in formerly communist Romania after 1989.

Furthermore, over the last years, East European consumers seem to have become more and more "modern", demanding and complex (Balasescu, 2009), endorsing the fact that major changes happen in consumer evolution of developing ex-communist countries. Balasescu suggests that Romanian consumers evolved from being naïve in 1996, to being available in 2000, loyal in 2003 to exigent and demanding in 2006 (Balasescu, 2009), suggesting a trend of rapid, major changes. The present study intends to update the knowledge regarding Romanian consumers' materialism levels.

In general, materialism values and individuals are seen negatively, considered bad or even evil. Research shows that materialism is seen as a false path to happiness via consumption, a weakness arising from insecurity, a type of harmful competition for status through possessions, and a valuation of things over people. Despite these negative connotations of materialism, many studies show increasing consumption patterns and aspirations that appear as highly materialistic. In research, Romanians were the least likely to see materialism as a weakness (Ger & Belk, 1996). They tended to stress the utilitarian aspects of materialism, what Czikszentmihalyi and Rochberg-Halton called instrumental materialism. In this view, goods are purchased to accomplish tasks, and possessions are seen as means to an end (Czikszentmihalyi & Rochberg-Halton, 1978).

In a qualitative study that investigated how people in different countries understand materialism, Romanians expressed that consumption makes people feel more accomplished, secure and prosper. During the interviews, Romanian participants suggested that materialism is relative to others, and while most people were ok from the consumption

stand point during the communist regime when nobody had much, this have changed; now some people become affluent making the others feel much worse about their life (Ger & Belk, 1996, 1999).

Romanian respondents indicated security, independence, power as reasons why instrumental materialism can bring happiness. In contrast to the authoritarian control of the state, consumption is seen to offer freedom (Ger & Belk, 1999). Many respondents portrayed their consumption tendencies behind a connoisseur passion, and not accepting the vulgar, materialistic explanation for consumption. Justifications of connoisseurship, instrumentalism, or altruism, all implied that a more "normal" variant of materialism is bad for the person and society. However, most respondents were able to reconcile their own ostensive materialism prevalent in their culture, and for those who did not, the most common account was to deny (rightly or wrongly) that they are materialistic. The general view was that after the deprivation from the communist regime, Romanians feel able to be deserving of luxury and to avoid the guilt of having more. (Ger & Belk, 1999)

Romanians view of decency and morality seemed shaped by Marxist ideals that saw property and capitalism as crimes. While communism is generally lampooned by Romanians as a mistake, the Marxist ideals behind it are not easily put aside. Participants saw it easy to be a decent person when life had not challenged you – "but when life challenges you, you can't be the same and become mean, materialist, and selfish". Therefore, the only pragmatic alternative in Romania seems to be making as much money as possible in order to enjoy a richer material lifestyle. Respondents explained: "before the revolution a university teacher, though badly paid, was somebody. Now a university teacher without money is a fool", "Consuming less is a weakness. When you can't afford buying something and have to give up, giving up is to lose". With attitudes like this is easy to see why Romania scored ahead of a dozen other countries in Europe, Asia, North America and Oceania, on a quantitative measure of materialism (Ger & Belk, 1996).

Materialism is seen as an individualistic orientation, and altruism is seen as the negation of materialism. This is a reflection of the Marxist doctrine, as Marx argued consumption is justified when used for self enhancement (instrumentalism) or social enhancement (altruism), but not when it is turned into signs of wealth. As a result, respondents tried to excuse their materialistic consumption tendencies providing reasons such as social/media pressures or historical forces. For example, Romanians see materialism as a condition that has been forced upon them by the changes in the economy since the 1989 revolution. Ever since the revolution, consumption images and luxury products flooded the markets and means became available to acquire more products. At the same time, opportunities for earning more in forms of part time or entrepreneurship became available too. This is seen by participants as forcing a renunciation of culture, books or art in order to pursue purchases of consumer goods (Ger & Belk, 1999).

Non-materialistic individuals in Romania were seen to include painters and philosophers, but however romantic such lifestyles were to Romanian participants, most saw themselves as preferring material comfort. At the same time, idealism was seen as a luxury afforded by great wealth (Ger & Belk, 1999).

Overall, cross-cultural studies suggest that Romanians are the most materialistic of all countries studied, followed by the US, New Zealand and Ukraine. Germany, Turkey, Israel and Thailand were found moderately materialistic, while India and all European countries except Germany were found to be relatively non-materialistic. Sweden had the lowest overall scores. The general impression left by the focus groups was that “everybody” in Romania is or is becoming materialistic (Ger & Belk, 1996).

The Romanians and Ukrainians were the only group in which no one said “nothing” when asked what they feel bad about not owning. While most groups indicated cars, fashionable clothing items, a dwelling, computers and books, the Romanian and Ukrainian groups were distinctive in their answers, indicating

food, cigarettes, furniture or appliances, or grooming products (Ger & Belk, 1996).

Interestingly, shortly before German reunification, Germany had the lowest score in materialism (Ger and Belk, 1990, 1996). The post unification measurements show significant differences, Germany becoming significantly more materialist than shortly before. This supports the interpretation that cultural change and unsettled social conditions are associated with greater levels of materialism. Similar findings were seen in Ukraine, which further indicates that consumer desires may be stimulated by abrupt changes that make consumption a novel new possibility (Ger et al, 1993) (Ger & Belk, 1996) These countries, Germany, Romania, Ukraine, Turkey are undergoing drastic changes – these changes lead to an increase in envy, confusion, social mobility, norms changes, insecurity, social comparison and the tendency to want prestige symbols (Ger & Belk, 1996).

Considering the mix of affluent and non-affluent nations, neither national affluence nor Westernness could explain the findings (Ger & Belk, 1996).

## 2 The Study

A Romanian version of the instruments was administered to selected participants. The questionnaire was blind back translated into Romanian, and delivered online through Qualtrics.com. The participants were selected from MBA students in Bucharest, and upper middle management and executives from several large organizations to control the income variable. In total, 123 participants answered the questionnaire. The questionnaire was divided into eight parts. The first part was the materialism measure, the short 9-item Material Values Survey MVS version. The short MVS was followed by short 5-item CETSCALE, the cosmopolitanism 6-item scale, the 3-item perceived social status scale, the 6-item tendency to spend scale, the 4-item life satisfaction scale, and the 3-item quality consciousness scale, and demographic questions.

### 3 The Variables

#### Materialism (MAT)

Consumption is increasingly becoming a focal point in life throughout the world (Ger & Belk, 1996, 1999; Belk, 1988; Friedman, 1994; Ger, 1997; Miller, 1995). The growing cross disciplinary literature defines the happiness seeking consumption-based orientation as materialism: (Richins and Dawson, 1992; Brewer and Porter, 1993; Richins and Rudmin, 1994; Ger & Belk, 1999).

Economic materialism is a widely debated and scrutinized concept, which has no universally agreed definition. Materialism has been defined as an “importance a consumer attaches to worldly possessions”, possessions that “assume a central place in a person’s life and are believed to provide the greatest source of satisfaction and dissatisfaction” (Belk, 1985) or as “a mind-set ... an interest in getting and spending” (Belk, 1986, p.10). Some authors consider materialism to be a trait (Belk 1985, 1986, 1989...), while others support the view that materialism is a value (Richins & Dawson, 1992; Richins, 2004, 2011). However many differences and numerous are the views on the materialism concept, commonalities between the different perspectives on materialism can be found: materialism is generally seen as a life orientation to give precedence to economic values over other values such as freedom (Inglehart, 1981) that can be related to pleasure or happiness seeking and expectation (Atay, Sirgy, Cicic & Husic, 2009; Richins, 2011), self or relationship definition or expression (Rose & DeJesus, 2007), claiming status (Fitzmaurice & Comegys, 2006; Ger and Belk, 1999; Eastman, Goldsmith & Flynn, 1999), or as a symbol that represents being part of modern, Westernized society. For instance, Jalees (2007) found a significant relationship between perceived social status and materialism (Jalees, 2007; Fah, Foon, & Osman, 2011).

Rising incomes across the world, together with an increasing abundance of consumer goods acted as enablers for materialistic tendencies – Inglehart (1981) contended that more affluent societies emphasize less materialistic goals as they have satisfied low order needs, moving on

to more abstract, less materialistic goals (Belk, 1985). But these materialistic tendencies were found in ancient civilizations too, even in a form of conspicuous consumption (McKendrick, Brewer and Plumb, 1982). More distinctly, many societies leaned towards more materialistic behaviors after the World War II, as individuals were “yearning to acquire and consume” (Cushman, 1990, p.600). Today, “we consume even as we work to make money in order to consume” (Tatzel, 2003, p.405).

Goods can communicate information about their owners, advertising for example the health conscious, the adventurous traveler and other such associations. To help define one’s self concept, a consumer uses products that have meaning derived from culture to define the consumer as a group member or as individual (Hoyer & MacInnis, 2007). Products can thus symbolize membership or desired membership in various social groups (Fitzmaurice & Comegys, 2006). Fitzmaurice (2008) suggested that high materialism consumers also viewed possessions as a way to achieve happiness and wellbeing. Accumulated goods seemed to portrait success through ownership, as well as the quality of possessed goods (Fah, Foon, & Osman, 2011). He also cited Fournier & Richins (1991) who suggest high mat consumers were more likely to buy something that is readily visible to signal and affirm their own high status and success (Fournier & Richins, 1991; Fitzmaurice, 2008).

The desire to consume was suggested to be opposed by the willpower to resist, or the self-regulatory goals aimed at resisting temporary urges (Podoshen & Andrzejewksy, 2012). The pleasure seeking goals activated by exposure to consumption situations were generally linked by research to negative character traits such as low self esteem, immaturity, financial problems, consumer impulsiveness, negative well being, post purchase dissatisfaction (Podoshen & Andrzejewksy, 2012). High levels of impulse spending tendencies, related to efforts made to improve a negative mood state, were also associated with high materialistic inclinations (Watson, 2003; Podoshen & Andrzejewksy, 2012).

**Consumer ethnocentrism (CET)**

Prior research found significant emotional responses and country-specific animosities towards foreign products (Huang, Phau, & Lin, 2010). This portrayed that consumers tend to favor domestic products due to moral obligation, superiority, or attitudes of ethnocentrism (Nguyen, Nguyen, & Barrett, 2008). CET describes a general attitude in which an individual holds a strong belief and commitment/loyalty towards his/her own ethnic heritage in-group, and evaluates other groups (out-groups) from the in-groups's standpoint (Summer, 1906; Watchravesringkan, 2010). CET possesses predictive utility related to consumers' attitudes in relation to domestic and foreign made products (Shimp and Sharma, 1987). Thus, differences in product evaluations are influenced by CET (Shimp and Sharma, 1987; Shoham and Brencic, 2003; Wang and Chen, 2004; Watchravesringkan, 2010)

While globalization brought an increase in MAT, a strong resistance behavior had been seen. Ger (1999, p.65) observed that globalization "strengthens or reactivates national, ethnic, and communal identities". For marketers it is crucial to know how this reactions manifest in the market. De Mooij (2004) suggests that consumption is based on long term habits, and many consumers hold strong desires to uphold traditional local culture, defying global influences (De Mooij, 2004; Cleveland, Laroche, & Papadopoulos, 2009).

Ethnocentrism represents "the universal proclivity for people to view their own group as the center of the universe" (Shimp and Sharma, 1987, p.280). One's own ethnic or national symbols are objects of attachment and pride, whereas of others may be held with contempt (Cleveland, Laroche, & Papadopoulos, 2009). Research suggested that society openness to foreign cultures is amenable to supporting the acceptance of foreign goods and services, whereas aspects such as patriotism, conservatism and ethnocentrism impede the acceptance of such products (Shimp and Sharma, 1987; Kaynak and Kara, 2002).

To the ethnocentric consumer, foreign products represent economic and cultural threat. Ethnocentric consumers are willing to make

economic sacrifices by choosing local brands (Cleveland, Laroche, & Papadopoulos, 2009). This bias toward locally produced products is known as CET (Shimp and Sharma 1987) and represents another dispositional response to globalization (Cleveland, Laroche, & Papadopoulos, 2009).

Even as CET and MAT are not always strongly correlated, there are instances where they are, as in the case of Greek and Chilean samples (Cleveland, Laroche, & Papadopoulos, 2009).

**Cosmopolitanism (COS)**

Globalization led towards the rise of global cultures, where groups of people are more outward, global oriented rather than inward, local (Cleveland, Laroche & Papadopoulos, 2009). Transnational cultures consist of structures of meaning carried by social networks that are not based in any single territory (Hannerz, 1992; Cleveland, Laroche, & Papadopoulos, 2009)

Transnationals are intellectuals who travel frequently, are routinely involved with foreign cultures and are "at home in the cultures of other peoples as well as their own" (Konrad, 1984, p.208; Cleveland, Laroche, & Papadopoulos, 2009). They act as cultural brokers or gatekeepers, deciding "what gets in, and what will be kept out, ignored, explicitly rejected" (Hanners, 1992, p.258). These translational cultures have roots in the West; they are extensions or transformations of American or European cultures, though they may be penetrable by local meaning (Hannerz, 1992; Cleveland, Laroche, & Papadopoulos, 2009)

Regarding cosmopolitanism there is debate – some authors suggest predisposition at birth, other envision a personality trait, while others classify it as a learnable skill (Cannon and Yaprak, 2002; Cleveland, Laroche, & Papadopoulos, 2009)

Cosmopolitanism is a set of specific beliefs, attitudes and qualities related to openness to the world and to cultural differences (Hannerz 1992, p.252), and to competence in other cultures. For example, tourists are more spectators rather than participants (Cleveland, Laroche, & Papadopoulos, 2009).

If a while ago belonging to an elite class was a prerequisite for cosmopolitanism, now this is no longer the case given the globalization and the culture shaping power of the media. Today it is perfectly possible that a person to be cosmopolitan without ever leaving own country (Douglas and Craig, 2006; Cleveland, Laroche & Papadopoulos, 2009)

As cosmopolitans see themselves as less provincial and more international (Hannerz 1990), they may be more responsive to global consumer culture (Alden, Steenkamp & Batra, 1999). Therefore, they may be more likely to adopt products from other cultures and places (Cleveland, Laroche, & Papadopoulos, 2009). Furthermore, global culture has been linked to the increase in materialism (Ger and Belk, 1996; Johansson, 2004; Cleveland and Laroche, 2007; Cleveland, Laroche, & Papadopoulos, 2009)

Even though COS may not be always strongly linked to MAT, there are instances where there is a strong link between them, as in the case of Korean respondents (Cleveland, Laroche, & Papadopoulos, 2009), knowledge of it in the Ro market would help marketers to position, as COS has been suggested to be a style of consumption (Thompson and Tambyah, 1999).

#### 4 Analysis and Results

This section describes the findings of the study; first descriptive statistics of the sample of the study are reported. This is followed by descriptive statistics of the survey items. Inferential analysis of the study was conducted through confirmatory factor analysis of the three factors (MAT, COS and CET) and principal component analysis of all seven factors.

123 participants completed the survey, 64 male and 57 female. Participants were selected from different organizational levels; the majority of the respondents (30%) held middle management positions. Furthermore, participants were selected from different organizations and 75% of them worked within private organizations. Looking through the mean statistics of the question items, responses associated with COS had the highest ratings.

All of the variables were first explored through an exploratory factor analysis (Principal Component Extraction with varimax rotation via SPSS 21). This enabled identification of the relationship and reliability of the questions associated with each of the higher level factors. Looking through the data obtained from the principal component analysis, it is visible that six out of the seven variables have acceptable loading values onto each of the factors (Table 1). Reliability analysis of the seven factors were found to be MAT= 9 items,  $\alpha = 0.66$  that indicates a relatively low reliability; upon deleting question 4, this reliability will increase to  $\alpha = 0.74$ . CET=5 items,  $\alpha = 0.90$ , COS=6 items,  $\alpha = 0.87$ .

The only factor that seems to not comply with this condition is MAT (Table 2). Looking through the loading of different questions in a factor plot (Figure 2) it seems that there is a need to delete MAT4 in order to normalize the distribution of the question on the MAT.

The factors were investigated through a confirmatory factor analysis (AMOS 20). The baseline measurement model for the entire data set (Figure 1) shows a good fit to the data (CFI=0.98, RMSEA= 0.074). Correlations between the latent factors were modest, with COS-MAT not significant ( $r = -0.04$ ,  $p < 0.001$ ) and MAT-CET not significant ( $r = 0.1$ ,  $p < 0.001$ ) and COS-CET not significant ( $r = 0.02$ ,  $p < 0.001$ ).

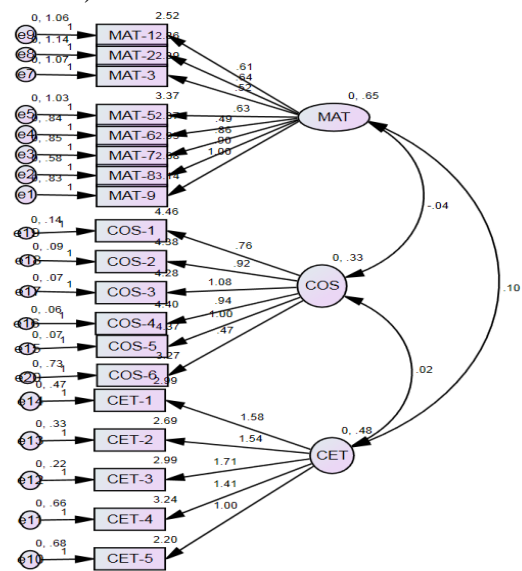

Figure 1. Baseline Measurement Model

Further correlations were conducted to facilitate the investigation of the relationship between each of the factors and MAT, COS, CET.

Participants scored MAT-5 the highest (Mean=3.37) and there was a wide range of responses for MAT-4 (Std=1.2). Conducting Pearson correlation revealed significant negative relationship between MAT3 and respondents' position, Pearson  $\chi^2$  (4, N = 123) = -0.293,  $p \leq 0.05$ ] and there was a significant negative relationship between MAT9 and gender Pearson  $\chi^2$  (4, N = 123) = -0.263,  $p \leq 0.05$ ] and between MAT9 and position Pearson  $\chi^2$  (4, N = 123) = -0.224,  $p \leq 0.05$ ] and between MAT9 and age Pearson  $\chi^2$  (4, N = 123) = -0.207,  $p \leq 0.05$ ]. Furthermore, there was a significant negative relationship between MAT8 and age Pearson  $\chi^2$  (4, N = 123) = -0.183,  $p \leq 0.05$ ].

Looking through the data obtained from consumer ethnocentrism, the data showed similar high score for CET4 (Mean=3.24) and the data obtained for CET1 showed a higher variety of scores (Std=1.29). Conducting a correlation analysis between the items of CET and age, education level, gender, age, position and organization) showed no significance.

The data obtained regarding Cosmopolitanism (COS) showed that respondents had higher scores for COS1 (Mean=4.46) and wider range of responses for COS6 (Std=0.897). Conducting Pearson correlation between the items associated with COS and age, gender, position, education level and organization showed significant negative relation between gender and COS4, COS5 and COS6). Furthermore, there is a significant negative relationship between position and COS4 and COS6.

## 5 Significance and limitations

The rationale for studying differences in materialism is that resulting knowledge and measurement may be useful in examining human and social impact of this aspect. Beyond consumption, materialism will influence the allocation of a variety of resources, including time (work longer hours to earn more money) (Richins & Dawson, 1992).

Materialists exhibit more self-centered traits and are inclined to construct meaning from immaterial (Chang & Zhang, 2008) and material goods (Cleveland, Laroche, & Papadopoulos, 2009). Conspicuous consumption can be seen as compensatory – making up for societal or situational marginalization (Podoshen & Andrzejewksy, 2012). Therefore, materialistic tendencies vary across different consumers, and also across different consumption contexts. This is specifically important as in addition to the materialistic tendencies, the context must also be analyzed to draw more meaningful conclusions regarding to what combination of context and individual tendencies will drive consumption behaviors (Rose & DeJesus, 2007). This contradicts the theory of the cognitive-affective personality system (Mischel & Shoda, 1995), who suggested that although behavior varies as a function of situation, individuals maintain enduring motives that interact to produce behavior, giving personality consistency.

Young professionals and MBA students were used as respondents to keep some individual difference variables such as age, education, and socioeconomic status relatively homogeneous. Such homogeneity is desirable in order to make meaningful comparisons with other cross-cultural studies (Ger & Belk, 1996). Socioeconomic status is an important confounding variable in cross-cultural psychology. The tradeoff is that demographic comparisons are narrower due to the limited range of demographics characteristics sampled. Another limitation is that business student and upper management samples may not reflect the broader patterns of materialism in Romania.

## References

- Balasescu, M. (2009). Evaluating buying behaviors on the consumption goods market in Europe and Romania. *Bulleting of the Transilvania University of Brasov*, 11-16.
- Belk, R. (1985). Materialism: Trait Aspects of Living in the Material World. *Journal of Consumer Research*, 265-280.
- Cleveland, M., Laroche, M., & Papadopoulos, N. (2009). Cosmopolitanism, Consumer Ethnocentrism, and Materialism: An Eight-Country Study of Antecedents and

Outcomes. *Journal of International Marketing*, 17 (1), 116-146.

Czikszenmihalyi, M., & Rochberg-Halton, E. (1978). Reflections on Materialism. *University of Chicago Magazine*, 70 (3), 6-15.

Fah, B. C., Foon, Y. S., & Osman, S. (2011). An Exploratory Study of the Relationships between Advertising Appeals, Spending Tendency, Perceived Social Status and Materialism on Perfume Purchasing Behavior. *International Journal of Business and Social Science*, 2 (10).

Ger, G., & Belk, R. (1999). Accounting for materialism in four cultures. *Journal of Material Culture*, 183-204.

Ger, G., & Belk, R. (1996). Cross-Cultural Differences in Materialism. *Journal of Economic Psychology*, 17 (1), 55-77.

Herman, E. (2008). The influence of final consumption on employment in Romania. *Annals of the University of Oradea, Economic Science Series*, 873-878.

Huang, Y., Phau, I., & Lin, C. (2010). Consumer animosity, economic hardship, and normative influence:

how do they affect consumers' purchase intention? *European Journal of Marketing*, 909-937.

Nguyen, T., Nguyen, T., & Barrett, N. (2008). Consumer ethnocentrism, cultural sensitivity, and intention to purchase local products. *Journal of consumer behavior*, 88-100.

Podoshen, J., & Andrzejewksy, S. (2012). An examination of the relationships between materialism, conspicuous consumption, impulse buying and brand loyalty. *Journal of Marketing Theory and Practice*, 20 (3), 319-333.

Richins, M., & Dawson, S. (1992). A Consumer Values Orientation for Materialism and Its Measurement: Scale Development and Validation. *Journal of Consumer Research*, 303-316.

Watchravesringkan, K. (2010). Exploring antecedents and consequences of consumer ethnocentrism: evidence from Asian immigrants in the US. *International Journal of Consumer Studies*, 383-390.

### Author description

Dr. Bogdan Robert IOANE completed his doctoral studies at SMC University Switzerland. His research interests are cross cultural management and cross cultural investigations in consumer behavior. He participated in several research projects in the above fields.